



# Des Moines WoodTurners Chapter Meeting Announcement & Newsletter

May 2026 a 501(c)(3) Non-profit Organization Bulletin 2026-05

## May 9th Demonstration ----- Brian Noble-Marx

### Morning Demonstration at 10 AM ---- Ovoid Bowl

This demonstration will illustrate the process needed to create a multi-axis ovoid bowl. It will include blank preparation between centers, faceplate mounting techniques and the math equations needed to find the solid foundation for a good form. Starting with a blank between centers, calipers will be used to insure the symmetry of the form. A discussion of the relationship between the diameters at the ends of the form and the end result of the curvature of the bottom of the bowl. Next the form is split in half and mounted to a face plate to achieve the gentle swing of the face of the bowl. The bowl gouge and spindle roughing gouge are the primary tools used throughout the demonstration. Ovoid bowls can be made in length from 6" to the maximum swing of the lathe.



### Afternoon Demonstration at 1 PM ---- Lidded Box

Brian will turn a lidded box from one piece of wood. This process happens by working into the end grain to first form the lid. Then the lid is turned around and fitted to the body of the box. The remainder of the form is established and then hollowed. Now the form is finalized and cleaned up. The end result is a box with a continuous grain pattern. Through the use of multiple types of gouges, scrapers, skew and a parting tool this box is a great one session at the lathe project.



## **Brian Noble-Marx Biography**

Raised in Springfield, Virginia, Brian's love for woodworking has been cultivated by many skilled woodworkers and artisans, supportive family and friends, and his own unique experiences. As a child, the family often took trips that led them across the United States and to other countries. The cultural influences of these unique places became an earmark to his artwork.

Brian has been woodturning since 1995 after Mark Gardner taught him to turn bowls. He has been doing fine woodworking since 1993, which encompasses a diverse range of skills. In addition to turning, he enjoys furniture making, clocks, boxes, carving, and marquetry. He received a Bachelor's of Fine Arts from Virginia Commonwealth University in 1996.

Brian's pieces are unique because of his ability to work with so many different forms of woodworking. His training in silversmithing, metalsmithing and metal spinning allows him to create a variety of accents to his custom pieces.

Brian resides in Midlothian, Virginia with his wife and two sons.



**Brian's Website: <https://noblemarx.com/>**

### **Training Class Update**

The number of students in the training classes will increased from 4 to 5. I will be in touch with the currently enrolled students to determine if moving to an earlier class is desired.

### **Future Educational Programs**

Sept. 12: TBA

October 10: Phil Holtan returns

## **Notes from the President Dennis Anderson**

We continue to search for a new club meeting location as the time to remain at Valley West Mall is counting down. A final deadline for mall closure has not yet been communicated. As of April 2026, the City of West Des Moines is moving forward with plans to redevelop the mall, potentially involving demolition, though final sale agreements are still being finalized. Our current lease will go month-to-month with sudden death after May 31. Your board continues to search many resources to find a location suitable to our club needs and budget.

I am asking for club member help to expand the search for possible locations. Please ask your business contacts and let a board member know if you find a location or perhaps a business partner that has suitable space we can rent for demonstration meetings.

The Iowa State Fair is August 13-23. The deadline for wood turned entries into judging is July 1. I want to encourage many club members to enter at least one item this year. Entries let the public see a variety of things our club turns of all skill levels.

Exhibitors are limited to two entries in each class and all entries must have been made by the exhibitor within the last five years. More information including class categories, fees, and forms is online at: [Iowa State Fair 2026 Wood Projects](#).

### **Des Moines Woodturners thanks Phil Laudenklos and Dave Bishop**

**Phil** generously donated 24 high end writing instruments for sale at the Fair.

**Dave** generously donated several woodworking tools for sale or door prizes.

### **DWMT Board Meeting ++All are Invited++**

Board meetings are open to all members.

The next board meeting **May 27th** at approximately 10:30 AM at Valley West.

### **Membership News - New Member**

Mike Butterworth - Johnston

We currently have 192 members

### **Summer Meeting**

There will be a meeting on August 26th at 9:30 am

Refreshment volunteer needed.

WOOD PROJECTS

Cultural Center - Second Level, West Side
Superintendent - Brenda Rekenhaller, Des Moines

Wood Projects exhibits will be open to the public during building hours each day of the Fair.

For questions, please contact the Iowa State Fair Entry Department at 515-262-3111 ext. 243 or entryintern1@iowastatefair.org.

RULES

- 1. Iowa Family Living general rules and regulations apply in this department. In case general rules conflict with Wood Projects Department general or special rules, the latter shall govern.
2. SUBMITTING ENTRIES. Entries may be submitted online or by mail. Online entry and a printable Iowa Family Living entry form are available at: https://www.iowastatefair.org/. If entering online, payment will be collected at time of entry. If entering by mail, complete entry form and return it with full payment of all fees to: Iowa State Fair, Iowa Family Living Entry Department, PO Box 57130, Des Moines, IA 50317-0003.
3. ENTRY DEADLINE IS JULY 1. Entries must be submitted online or postmarked on or before July 1.
4. ENTRY FEE. Each exhibitor, as a requirement for entry, shall pay a fee of \$5 per entry.
5. LATE ENTRIES. An additional late fee of \$10 will be charged for all entries submitted online or postmarked July 2 - July 8. No entries will be accepted after July 8.

ENTRY ELIGIBILITY

- 6. Definitions:
Woodcarving - articles of wood sculpted or shaped with gouges, knives or hand held rotary tools.
Woodworking - articles made from wood.
Woodturning - articles of wood shaped on a lathe.
7. Exhibitors are limited to two entries in each class.
8. All entries must have been made by the exhibitor in the last five years.
9. Amateur and professional work will be eligible, regardless of state where made.
10. A youth (exhibitors age 18 and under) can enter an adult class; however, the entry will be judged as adult.
11. Machine (i.e. duplicating machine, carving machine, CNC or laser) created work can only be entered in one of these classes: roughouts, instructor assisted or anything goes.
12. Materials other than wood (i.e. trim, laser engraving or other ornamentation which should not be the major theme of the project) may be used to decorate or put finishing touches on a project provided these are kept to a minimum in the opinion of the judges.
13. If space allows, items having won a blue ribbon at the Iowa State Fair competition in previous years will be welcomed as a non-competitive entry for exhibition only.
14. Entries NOT winning a blue ribbon may be entered in the competition again.
15. No advertisements (products, events, websites, QR codes, etc.) are allowed to be placed with entries.

ENTRY TAGS

- 16. Entry tags will be mailed to you to be completed and placed on articles before shipment or delivery.
17. Exhibitor must indicate in which division and class the work is to be judged on the entry tag.

DELIVERY OF ENTRIES

- 18. Articles with entry tags attached will be received in the Cultural Center from 9:00 a.m. to 4:30 p.m. on Saturday, August 8. No article received after 4:30 p.m. on Saturday, August 8 will be accepted for judging. You will need a Pre-Fair permit to bring your vehicle onto the Fairgrounds to drop off your exhibit(s). This will be sent with your tags.
19. Articles entered may be sent by mail. For standard mail, send to: Iowa State Fair, Wood Projects Department, PO Box 57130, Des Moines, IA 50317. For UPS or FedEx, send to: Iowa State Fair, Wood Projects Department, 3000 East Grand Avenue, Des Moines, IA 50317. Package must be received by 4:00 p.m. on Friday, August 7. In no case will packages be received and articles placed on exhibition unless all charges are prepaid.
20. All hanging items need to have a hanger attached that is sufficient to hold the item hanging for the entirety of the Fair.

JUDGING

- 21. The Superintendent or Judges may use his/her discretion in placing articles in another class. Awarding of ribbons will be at the Judges' discretion.
22. Honorable Mention ribbons will be awarded at Judges' discretion.
23. Judging will be as follows:

WOODCARVING

Table with 2 columns: Category and Percentage. Rows include Realism (.25%), Creativity (.25%), Construction, Workmanship, Joinery (.25%), Finishing (.25%), and TOTAL (100%).

**IOWA STATE FAIR \* AUGUST 13-23, 2026 \* WOOD PROJECTS**

**WOODWORKING**

Originality.....	15%
Functionality.....	15%
Aesthetics, Choice of Material.....	20%
Construction, Workmanship, Joinery.....	25%
Finishing.....	25%
TOTAL.....	100%

**WOODTURNING**

Overall Design Appeal.....	5%
Creativity.....	10%
Workmanship.....	35%
Finishing.....	50%
TOTAL.....	100%

24. Judges' decisions will be final.

**RECLAIMING ENTRIES**

25. **NO ARTICLES WILL BE RELEASED FROM THIS DEPARTMENT UNTIL 7:15 P.M. ON SUNDAY, AUGUST 23.** Articles may be picked up at the exhibit area on Sunday, August 23 from 7:15 p.m. to 9:00 p.m. or on Monday, August 24 from Noon to 6:00 p.m. Admission will be charged at the gate on Sunday, August 23 with no on-site ticket sales and no entry/re-entry allowed after 7:00 p.m. You must be on the Fairgrounds by 7:00 p.m. on Sunday, August 23. **Vehicle permits are required for admittance of vehicle on the inner Fairgrounds, August 13-23.**
26. Beginning Wednesday, August 26 and until Friday, September 4, articles can be picked up in the Entry Department located on the lower east side of the Administration Building. Hours are 9:00 a.m. to 4:00 p.m. on weekdays and 11:00 a.m. to 2:00 p.m. on Saturday, August 29 and Sunday, August 30. (Please note: Entries will not be available for pick up on Tuesday, August 25.) **After September 4, all unclaimed items become the property of the Iowa State Fair and will be disposed of as deemed necessary.**
27. Articles will be returned by mail or UPS providing return postage is furnished to the Superintendent. Please provide a pre-paid shipping label.

**LIABILITY**

28. The Management will use diligence in caring for the safety of entries after their arrival and placement, but in no case will they be responsible for any loss or damage that may occur.

**AMERICA 250 AWARD**

All entries that showcase the patriotic spirit of America 250 (i.e. flags, Red, White, and Blue, etc.) will be eligible for a special America 250 premium of \$25 in addition to regular premiums. Awards will be selected by a panel of judges from blue ribbon recipients. Entries will be designated as America 250 award eligible by exhibitors at check in. Departments eligible for the America 250 Award include: Creative Arts & Crafts, Doll Houses & Miniature Rooms, Fabric & Threads, Fine Art, Floriculture, Food, Photography and Wood Projects.

**SPECIAL AWARDS**

Awards of cash, merchandise or merchandise certificates will be given from the following friends of Wood Projects:

**In memory of Roger Bean**, Oskaloosa IA - \$10 will be awarded to 1<sup>st</sup> place in the following ten Classes: 2, 4, 10, 12, 16, 30, 32, 40, 43 & 46

**Darrell & Margie Brown**, Des Moines IA - monetary prizes totaling \$500 will be awarded in Wood Projects Classes.

**Des Moines Woodturners, Inc.**, Des Moines IA - monetary prizes totaling \$300 will be awarded in Woodturning Classes.

**Des Moines Woodworkers Association**, Des Moines IA - monetary prizes totaling \$250 will be awarded in Woodworking Classes.

**Wildlife in Wood - Debbe Edwards**, Bluejacket OK - \$50 will be awarded to 1<sup>st</sup> place in Class 1 (Animals Domestic, Realistic) and \$50 will be awarded to 1<sup>st</sup> place in Class 31 (Wildlife, Realistic Predators)

Additional awards to be announced.

**IOWA STATE FAIR \* AUGUST 13-23, 2026 \* WOOD PROJECTS**

**WOODCARVING - DIVISION 800**

**Premiums ..... 1<sup>st</sup>-\$10; 2<sup>nd</sup>-\$5; 3<sup>rd</sup>-Ribbon**  
 Best of Show ..... Rosette

**ANIMALS DOMESTIC**

- 1 Realistic
- 2 Caricature

**HUMAN FIGURES**

- 3 Realistic
- 4 Caricature

**ABSTRACT**

- 5 Non-Objective

**STYLIZED - Any Subject**

- 6 Human Figure
- 7 Animal
- 8 Other (i.e. bowl, vessel)

**MISCELLANEOUS**

- 9 Jewelry
- 10 Canes and Gunstocks
- 11 Chip Carving
- 12 Woodburning
- 13 Miniatures (2" x 2" x 2")
- 14 Functional (frames, clocks, etc.)
- 15 Bark Carving and Cyprus Knees
- 16 Seasonal Decorative (all seasons, including Santa and Christmas ornaments)
- 17 Other (i.e. signs)

**WHITTLED PIECES**

- 18 Chains, Ball & Cages (made with knife and single piece of wood)

**DECOYS (Will not be float tested)**

- 19 Ducks & Geese Floating
- 20 Shore Birds
- 21 Other Waterfowl
- 22 Working Decoys

**WILD FOWL**

- 23 Birds of Prey
- 24 Songbirds
- 25 Upland Game Birds
- 26 Miniature Birds (1/2 size or less and no larger than 6")
- 27 Birds (group or pair)

**NOVICE ADULT - Any Category**

- 28 Novice Adult - limited to any first year carver age 18 & over

**YOUTH - Any Subject**

- 29 Youth - carvers age 12 & under
- 30 Youth - carvers age 13-18

**WILDLIFE**

- 31 Realistic Predators
- 32 Caricatures
- 33 Other Animals
- 34 Fish/Sea Mammals

**RELIGIOUS CARVING**

- 35 All Types

**RELIEF CARVING**

- 36 Scenes portraying historic architecture
- 37 Nature Scene (landscapes)
- 38 Natural History (birds, fish, animals, etc)
- 39 Scene (other than nature)
- 40 Human Subject

**GROUP CARVINGS**

- 41 Group Carvings - multiple carvings in one setting, including scenes or depictions with multiple carvings in the round and including ducks & geese (group or pair)

**INSTRUCTOR ASSISTED**

Instructor Assisted (seminar pieces) - any carving carved with instructor's knowledge or assistance

- 42 Birds
- 43 Human
- 44 Wildlife
- 45 Other

**ROUGHOUTS**

Roughouts (purchased shape) - originality in changing the shape of original artist's intent to self-expression will add to points awarded by judges

- 46 Human
- 47 Other

**SENIOR CITIZEN**

- 48 Senior Citizen Project - carvers age 65 or older

**WOODWORKING - DIVISION 801**

**Premiums ..... 1<sup>st</sup>-\$10; 2<sup>nd</sup>-\$5; 3<sup>rd</sup>-Ribbon**  
 Best of Show ..... Rosette

- 49 Clocks
- 50 Furniture Item
- 51 Functional Item (boxes, cutting boards, wall art, frames, jewelry, tools, etc.)
- 52 Intarsia
- 53 Luthier Class (instrument)
- 54 Model

- 55 Scroll Saw
- 56 Seating (chair, bench, stool, etc.)
- 57 Table
- 58 Wood Toy
- 59 Next Generation - under the age of 25
- 60 Anything Goes (other, CNC, laser, etc.)

**WOODTURNING - DIVISION 802**

**Premiums ..... 1<sup>st</sup>-\$10; 2<sup>nd</sup>-\$5; 3<sup>rd</sup>-Ribbon**  
 Best of Show ..... Rosette

- 61 Bowl
- 62 Box (any type of lid)
- 63 Hollow Vessel
- 64 Kit Items (pen, pencil, seam ripper, spice mill, etc.)
- 65 Natural Turned Item (bowl, vessel or platter with natural voids or live edge)
- 66 Functional Items (rolling pin, jewelry, games, toys, etc.)

- 67 Seasonal (any seasonal item, ornament, tree topper, etc.)
- 68 Segmented Turned Item (bowl, vessel or platter)
- 69 Open Segmented Turned Item (bowl, vessel or platter)
- 70 Embellished Turned Item (colored, textured, carved, pyrography, resin, etc.)
- 71 Stylized (sculptured)
- 72 Any Other Turned Wood Project

## **Don Kruse Demonstration, April 11, 2026 Inside-Out Lamp**

**Don Kruse** began the demonstration by telling us he has taught wood lathes to students for 35 years since 1969. He showed pictures of wooden lamps and liked making them. He joined the Des Moines Woodturners after moving to Iowa.

He first began by making lamp prototypes by using less expensive 2x4's. **Don** passed out a 4-page instruction sheet with the directions on how to make inside out lamps. He showed several lamps he had made with the inside out design. He suggested beginning by cutting four 1 ½ inch square lumber pieces 14 inches long for the outside of the lamp and one 16 inch long 1 ½ inch square piece for the center of the lamp. He cautioned turners about the importance of smooth surfaces and exact dimensions. They all get glued together with the longer spindle in the middle of the four shorter pieces. He used paper glued to the wood spindles to make it easier to separate them after turning. He also used graph paper to draw out the shapes to be used to guide the parting cuts.

He made cuts to the outside of the glued-up section using traditional and carbide lathe tools. He began the cuts using a parting tool to set the depth of the cuts and lather tools to cut away the waste wood on the outside spindles. He sands and finishes the outside cuts before they are separated as finished is difficult if you wait until they are put together in the finished form. He separates the spindles and uses the center longer spindle to design a unique center object for the lamp center. The turner can make many different shapes for the center object and make the lamp as unique as desired.

The pieces are then glued together in final form and the outside it then turned to the shape desired. If the pieces are all dimensioned correctly the outside edges will be uniform. The lamp can then be finished by the turners in many ways.

**Don Kruse** demonstrated to the group the basic steps in making an inside out lamp to enable turners to use them as a method to make lamps of many different forms as unique as the turner wants to make them. Using the directions and methods of construction, Des Moines Woodturners have the information they need to make their own lamps.



**Will Zitterich**, Club Secretary

## **Support the Club - Turn Trees and \$3 Pens for the State Fair**

The greatest need is **Trees** and **Funky Pens**.

The trees should be at least 6 inches tall, but otherwise no limits.

The Funky Pens sell for \$3. So, don't spend a lot of time.

Tree and Funky Pen blanks are available at Valley West.

1. Decide on a small curve or a large curve. The difference is the size of the wood to start with. These directions are for the small curve.
2. Small curve use 1.5" x 1.5" x 14" Large curve use 1.5" x 2" x 14".
3. Decide on the type of wood. These directions will be for Walnut and Maple.
4. Cut list. This **does not** include the base.
  - a. 1 – 1.5" x 1.5" x 14 3/4" Pine that will not be part of the finished lamp.
  - b. 4 – 1.5" x 1.5" x 14" Walnut – These are the sides. A, B, C & D
  - c. 1 – 1.5" x 1.5" x 4" Walnut- This will make the middle.
  - d. 2 – 1.5 x 1.5 x 5.25 Walnut – Top and bottom for the middle section
  - e. 1/4" thick Walnut and Maple for the middle round part.
    - i. After the glue up this will be 4" long and 3" wide.
  - f. 1 – 1.5 x 1.5 x 18" Maple – the four corners on both ends.
5. Take the 1.5" square Pine and glue the 4 Walnut to it. Only glue 2" at the ends with **brown paper inbetween**. Leave 1/4" of the pine sticking out each end to create a tendon. **Mark one end of the walnut with A, B, C and D**
6. Attach to lathe using a chuck on the head stock. Use the tail stock for support.
7. Use the template and mark the curve. Bottom of curve should be 3/8" above the bottom.
8. Mark the center at 7". From this point measure a distance of 5" both ways.
9. Using the parting tool at the center go to a depth of just above the curve.
10. Remove wood almost down to the curve.
11. Check often to make sure the template is fitting in the curve.
12. When the curve is completed, sand it smooth and put final finish on it. This curve will be the inside. When satisfied with the finish set it aside. While the finish is drying start on the center section.

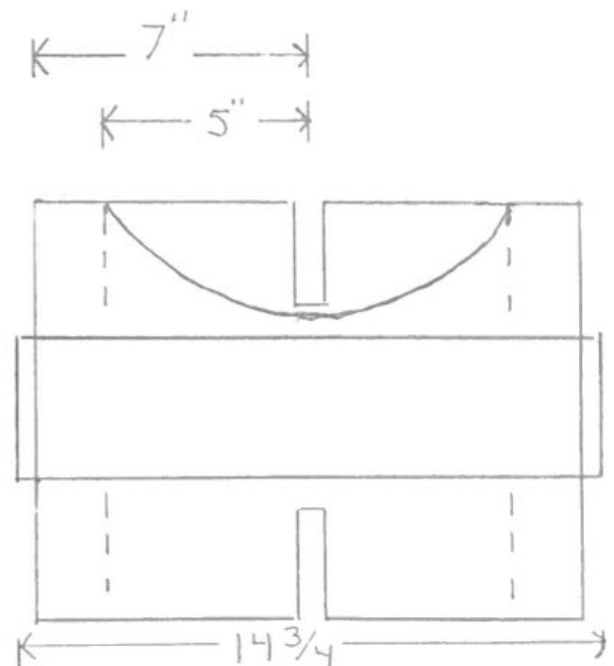
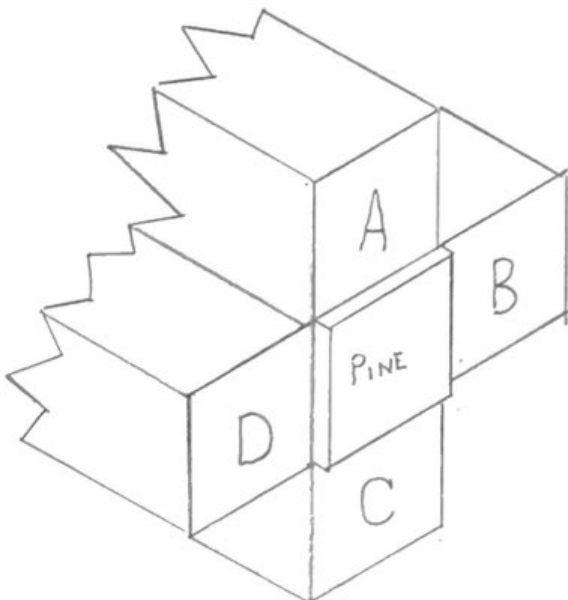

## THREE SECTION CENTER

### CENTER

13. Use the 4" Walnut. This will be the center section.
  - a. Build this up using the  $\frac{1}{4}$ " Walnut and the  $\frac{1}{4}$ " Maple. Keep adding layers till this is 3" square. If a little bigger that is ok.
14. Once it is 4" long and 3" square put in the chuck and use the tail stock.
15. Put a 1" diameter tendon on the tail stock end that is only  $\frac{1}{8}$ " out. Turn the center section to the desired shape.
16. Drill  $\frac{5}{8}$ " hole into tendon  $\frac{1}{4}$ " deep.
17. Change chuck jaws to pin jaws. Reverse the center section and add a tendon to this end.
18. Drill  $\frac{5}{8}$ " hole into tendon  $\frac{1}{4}$ " deep.
19. Drill  $\frac{1}{2}$ " hole all the way thru.
20. Sand center section to 220 grit.

### TOP AND BOTTOM SECTIONS

21. Top and bottom sections are the same size. 2 – 1.5 x 1.5 x 5.25
22. Mark 2.25" in from the end that is going into the chuck. Make a mark on the other end that is  $\frac{5}{8}$  diameter.
23. Turn the end down to the  $\frac{5}{8}$ " mark and make it  $\frac{1}{4}$ " wide. Better to make this to big than make it to small. This end will be glued into center section.
24. Taper this section from the 2.25" line to the end.
25. When you have it close to what you want check for fit on the middle section. It should fit very snug.
26. After it fits drill  $\frac{1}{2}$ " hole in from the tapered end 3".
27. Sand to 220 grit.

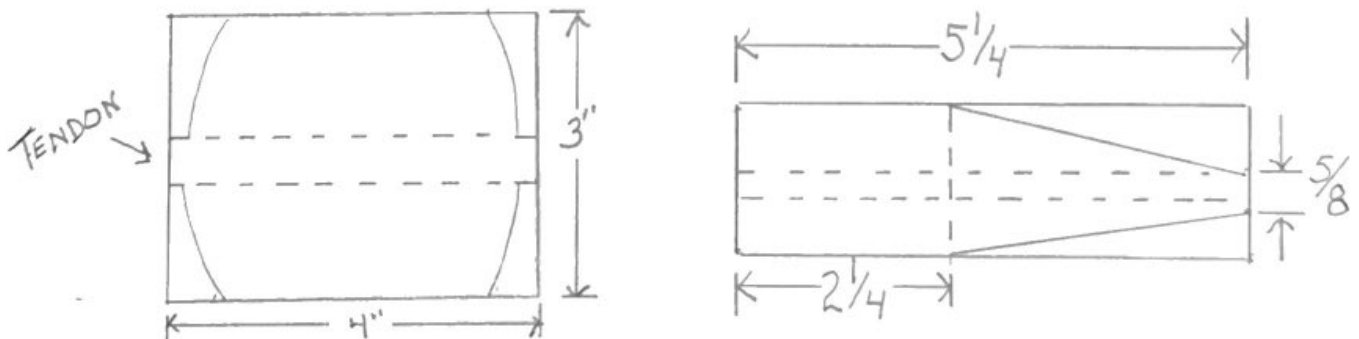

28. Line up the center section on part A. Clamp and glue the center section together.

29. Now put the entire center section back on the lathe and do the final shaping and sanding.
30. Put your final finish on the center section.
31. Using a chisel to separate parts A, B, C & D. No need to sand the paper off.
32. Line up the center section on part A. Clamp and glue the center section together.

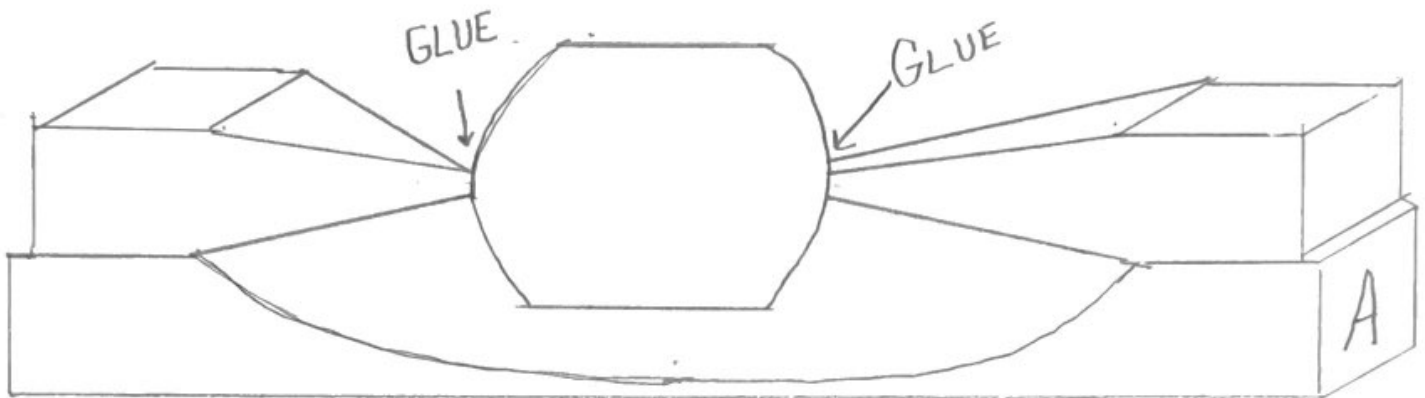

33. Glue parts A, B, C & D to the middle section. Make sure **all the marked ends** are on the same end.
34. Add blocks 1.2" x 1.5" x 2" to the 4 corners on each end. Make sure you have a 1/4" tendon to chuck up.

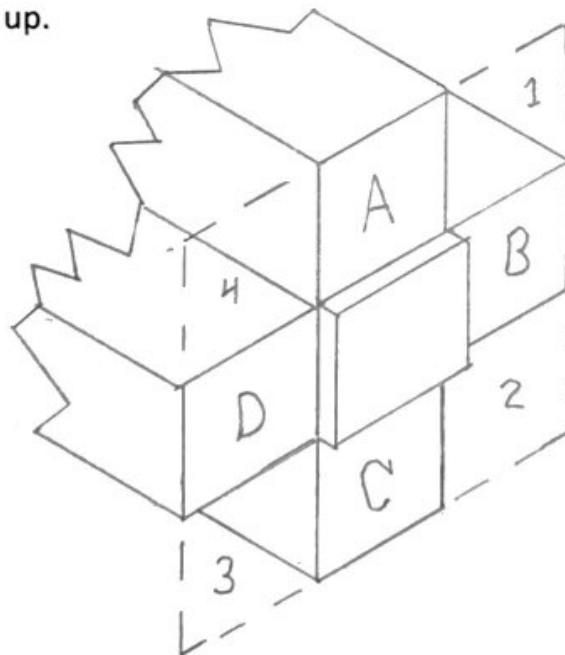

35. Mount on lathe.
36. Turn both ends round.
37. Use parting tool next to one end and remove wood down to where the sides come into the middle shaft.
38. Start in the middle and form the side down to the end.

39. When satisfied with shape do the other end to match. Start with the parting tool.
40. Shape the top and bottom.
41. Make segmented rings for the base if you want added height.
42. Glue rings to base.
43. Shape the base.
44. Sand entire lamp.
45. Use  $\frac{1}{2}$ " spade bit and drill out the remaining hole in the base tendon.
46. Finish sanding the entire lamp.
47. Use cole jaws to remount the lamp with the base on the head stock.
48. Drill out the top with  $\frac{1}{2}$ " spade bit.
49. Take tendon down to 1" diameter and do final shaping and sanding.
50. Drill  $\frac{1}{4}$ " hole for the wire in the segmented ring on the back side.
51. Wire the lamp up.

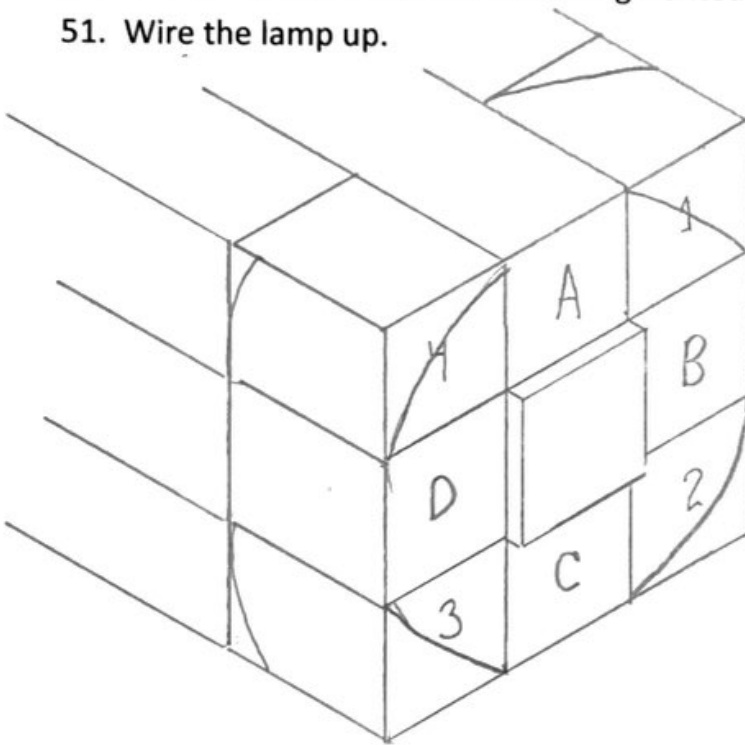

#  
36

#  
37

Parting Tool

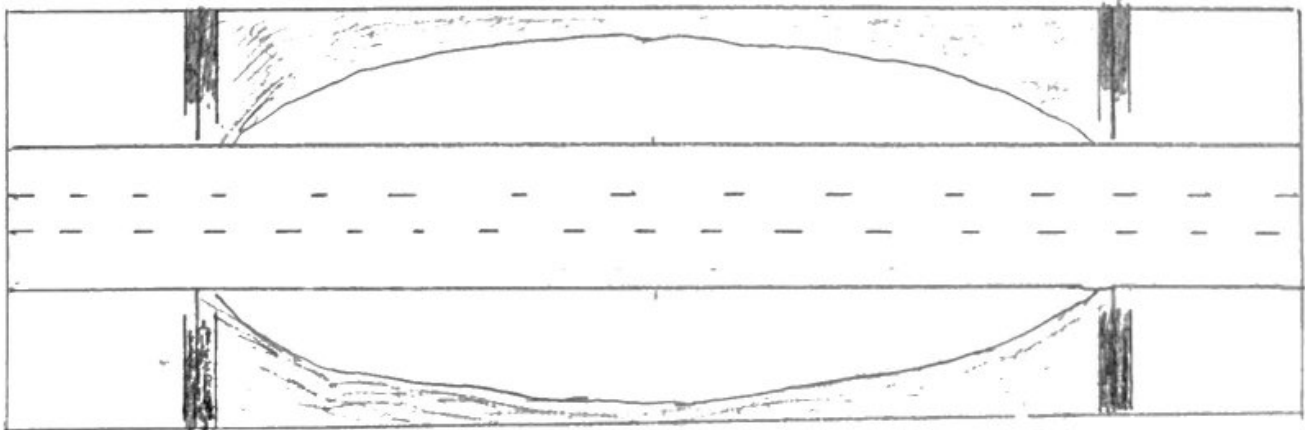

## DMWT You Tube Channel

Our dedicated club videographer, **Tom Baker**, has been working tirelessly to create a YouTube channel for our club videos. Currently, there are a handful of videos available, and Tom will continue to add more, starting with the most recent recordings and working back to older ones.

Please note that not all videos from our meetings may be uploaded, primarily because many professional turners monetize their demos and may not grant us permission to share those recordings on our channel.

We encourage you to subscribe to our YouTube channel, as this will not only keep you updated on the latest content but will also enhance our visibility on the platform.

Here's the link to our channel:

[Des Moines Woodturners YouTube Channel.](#)

We believe you will appreciate the effort **Tom** is putting into this project.

Be sure to subscribe and enjoy the videos!

## Tool Exchange and Sale - Each Wednesday Morning Networking Meeting

Do you have extra woodworking tools sitting unused in your shop?

Want to trade them for something new or clear some space?

The Rules:

- **Members Only:** Participation is restricted to current club members.
- **Private Sales:** All money or trade negotiations are strictly between the buyer and seller.
- **Woodworking Focused:** Items must be related to wood-related tools or accessories.
- **Size Limits:** Items must be small enough to carry in. For larger machinery, please leave it in your vehicle and bring a photo to display.
- **Setup:** Tables will be provided in the meeting room for your items.
- **Labeling:** Please clearly mark each item with the seller's name and asking price.
- **Clean Up:** All unsold items must be taken home at the end of the meeting.

## Turning Blanks for the Iowa State Fair Only

The Dick Meuler sale was very successful, however there is a lot of wood left. The family has donated this to the woodturners and woodworkers. Several pieces have been taken to the mall. As always, the wood in the very back room where the restroom is free for the taking. Several nice pieces have been placed there.

Other pieces are back by the treasurer's desk that are only for the state fair and are to be checked out through **Mark Hayes**. Some very nice turning pieces are there. Hopefully you can help us out with turning an item for the fair.

## Training News

### Woodturning Classes

**General Information:** You will receive an information packet by email approximately 1 month before the class. It contains a list of required accessories, location and safety information. A reminder will arrive about 1 week before the class. The fee is collected on the day of the class. There is no penalty for cancellation, but please let us know ASAP if you have to cancel.

**Basic Woodturning:** If you have not taken Basic Woodturning you will find it useful if you're new to turning, been away from the lathe for awhile or would just like a refresher. Enhance your spindle turning skills. It is a fun day and a confidence builder. In addition, it is the prerequisite for the other courses. DMWT provides the tools and wood. Homework is assigned between classes so you will need access to a lathe. Basic Woodturning is two consecutive Mondays, 8:30 to 5. Cost: \$40.

**Basic Bowl Turning:** This class touches on basics of wood harvesting, differences from spindle turning, and introduces the bowl gouge. You will practice on a Poplar blank before turning your Hard Maple bowl. The class is one full day. DMWT provides the tools and blanks, you provide the accessories and face shield. This is a one day class. Cost: \$20.

**Basic Segmenting:** This class will cover the basics of making segmented projects, from calculating segment angles and sizes, ring diameters needed, segment wood prep, gluing and clamping, to accurate cutting fixtures. You'll glue together furnished pre-cut segments and clamp them. Turning will be demonstrated but students won't be using the lathe in the class. Pre-cut segments for glue-up practice will be furnished. Bring paper and pencil to take notes. This is a one day class. Cost: \$20.

**Basic Skew Chisel:** This class will introduce students to the proper techniques and use of the tool as well as sharpening. Students will furnish their own skew chisel(s) (3/4 inch and up preferred). We will use the same accessories as in the Basic Woodturning Class. This is a one day class. Cost: \$20.

**Basic Sharpening:** The sharpening class will use lathe mounted sandpaper sharpening wheels and wooden dowels to teach the techniques of sharpening. This class is primarily for gouges but will also touch on a variety of other common traditional turning tools such as parting tools, skew, bedan and scrapers. In addition, sharpening hollowing tools, thread chasers, hook tools and common flat carbide cutters will be discussed. After practice, students will have the opportunity to sharpen their own tools using the Oneway Wolverine Sharpening system and CBN wheels. This is a one day class. Cost: \$20.

Please contact John Amberg at [johnaamberg@yahoo.com](mailto:johnaamberg@yahoo.com) for further information or to sign up.

### Are you signed up for a Woodturning Class?

Please check the Training Classes page. There have been a number of changes in class assignments. Please make sure you are in the right class at the right time. If there is an error, please email [John Amberg](mailto:John Amberg) ASAP.

## 2026 Training Classes

If you would like to enroll, email John Amberg at [johnaamberg@yahoo.com](mailto:johnaamberg@yahoo.com)  
or see me at the meetings.

All Classes are on Mondays from 8:30 am to 5 pm.

Basic Woodturning	Basic Woodturning	Basic Woodturning	Basic Woodturning
March 9 & 16th, 2026	April 20 & 27th 2026	September 14 & 21, 2026	October 19 & 26, 2026
Bob Jackson Tim Ingram Elijah Ingram Dustin Smith	Herman Riva Dennis Schneider Curt Barclay Dana Oredson	Kevin Roozeboom Larry Bailiff Gary Reed Kepler Johnson 1	Philip Blobaum Tim Devine Sharon Squibb 2 1

Basic Skew	Basic Segmenting	Basic Segmenting	Basic Skew
March 23, 2026	May 4, 2026	September 28, 2026	November 2, 2026
Herman Riva Scott Smith Mark Hayes Bob Jackson	Scott Smith Tom Golding Dana Oredson Sharon Squibb John Terry	Herman Riva Dustin Smith 3 2 1	Brent Heuer Curt Barclay Herman Riva Scott Core 1

Basic Bowl	Basic Bowl	Basic Bowl	Basic Bowl
March 30, 2026	May 11, 2026	October 5, 2026	November 9, 2026
Bob Jackson Tim Ingram David Breese	Sharon Squibb Dennis Schneider Curt Barclay Dana Oredson Gene Davis	Larry Bailiff Gary Reed Kepler Johnson Gene Davis 1	Philip Blobaum John Carman Tim Devine Dustin Smith 1

Basic Sharpening	Basic Sharpening	Basic Sharpening	Basic Sharpening
April 13, 2026	May 18, 2026	October 12, 2026	November 16, 2026
Tim Ingram Scott Smith Sharon Squibb Bob Jackson	Brad Huyser Jeff Newhook Curt Barclay Dana Oredson John Carman	Greg Alberts Herman Riva 3 2 1	Larry Bailiff Gary Reed Kepler Johnson Philip Blobaum 1

## Training Class Graduates

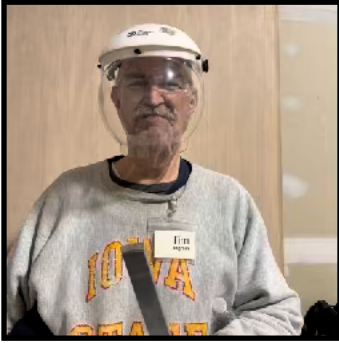

## Basic Sharpening, April 13 Tim Ingram, Bob Jackson, Dustin Smith, Sharon Squibb

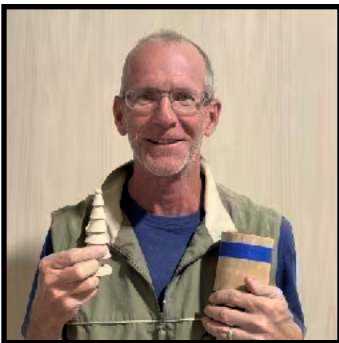

## Basic Woodturning, April 20 and 27 Herman Riva, Dennis Schneider, Curt Barclay, Dana Oredson

## Richard Raffan (re)joins the Funnel Club

<https://www.youtube.com/watch?v=eOP6AOHzPWQ>

Even the experts have a bad day.



## Mentoring Program

The Des Moines Woodturners Inc. (DMWT) invites members to use the Mentor Program. Below is a list of volunteers, members in good standing, who are willing to share their experience and answer specific questions to help you with a particular problem. Each mentor's strengths are noted along with their name and city location. Select who might be best to contact, based on your questions and how far they are from you. As volunteers, it will be up to the mentor to decide if they can help, whose shop will be used and what mentoring will look like based on the need.

Webpage: [DMWT Mentoring Program](#)

**Dan Carlson**, Clive  
Phone 515-720-0637  
[dano1466@yahoo.com](mailto:dano1466@yahoo.com)

Dan will mentor in these areas:

1. Getting started with pen turning
2. Turning small ornaments
3. Turning small lidded boxes
4. Turning seam rippers, letter openers
5. Turning bottle stoppers

---

**Glen Farmer**, Ogden  
Phone 517-395-0317  
[gfarmeriii@yahoo.com](mailto:gfarmeriii@yahoo.com)

Glen will mentor in these areas:

1. Bowl turning
2. Ornaments
3. Hollow forms
4. Coloring
5. Platters
6. Spindle work
7. Boxes
8. Harvesting wood/Blank cutting

---

**LeRoy Monson**, Wauke  
Home Phone: 515-987-1655  
Cell Phone: 515-745-9098  
[monsonlg@aol.com](mailto:monsonlg@aol.com)

LeRoy will mentor in these areas:

1. Spindle (including duplicating)
2. Bowls
3. Platters
4. Lidded box
5. One-way sharpening and set-up
6. Tool control
7. Bandsaw and lathe maintenance

**Tad Tadlock**, Winterset  
Phone: 515-201-7403  
[tad4tahoe@aol.com](mailto:tad4tahoe@aol.com)

Tad will mentor in these areas:

1. Natural & naked edge bowls
2. Large & small bowls
3. Platters
4. Boxes
5. Open void vessels
6. Sharpening

---

**Jack Kennedy**, Winterset  
Phone: 515-462-3141j  
[jkennedywinterset@att.net](mailto:jkennedywinterset@att.net)

Jack will mentor in these areas:

1. Closed Segment Bowls
2. Open Segment Bowls

---

**Jack Rolison**, Ottumwa  
Phone: 641-683-5647  
[jd.rolison@outlook.com](mailto:jd.rolison@outlook.com)

Jack will mentor in these areas:

1. Bowl turning
2. Finishing
3. Coloring
4. Sharpening

## Educational Opportunities

### DMWT Woodturning Scholarship

The Des Moines Woodturners offer a scholarship program for the benefit of chapter members. Woodturning can be an expensive endeavor. The cost of equipment such as a lathe, bandsaw, chainsaw, sharpening system, buffing system and the myriad of items like drive centers, scroll chucks, live centers, adapters, jaws, and faceplates can mount rapidly. In addition is the cost of turning tools, embellishing tools, specialty tools and a host of accessories, supplies and finishing products, not to mention the cost of wood if you don't have the capacity to harvest your own.

By the same token, three and five day woodturning educational events are also expensive when located out-of-state. Travel costs, lodging and tuition can easily run \$1,000 to \$1,700 per event.

This scholarship is not intended as a source of financial aid for those who might otherwise not be able to afford the educational experience. Instead, it is offered as an incentive to those serious about woodturning who are willing to expand their skills and knowledge and bring those skill-sets back to share with our members in a variety of ways. The scholarship can provide recipients a 25% to 50% discount toward the overall cost of their attendance expenses.

The purpose of the scholarship is to expand personal woodturning skills and knowledge and share their experience with fellow members by:

- Attending Chapter events and sharing their learning experience.
- Showing examples of their work as a result of their learning experience.
- Demonstrating what they learned at a chapter meeting, event, or class.
- Sharing their overall learning experience and confidence building experience.
- Encouraging members to expand their woodturning skills via similar educational experiences.
- Volunteering for Chapter leadership positions (wide variety of opportunities).

### American Association of Woodturners (AAW)

We recommend an AAW membership because it offers many woodturning resources:

- \*\* Six issues of American Woodturner magazine each year.
- \*\* On-line access to all previous issues of American Woodturner and FUNdamentals.
- \*\* On-line access to videos and many other learning resources.

[AAW Membership Join or Renew](#)  
American Association of Woodturners  
222 Landmark Center,  
75 5th Street  
W St. Paul, MN 55102

Phone: (651) 484-9094 direct or toll free US (877) 595-9094

Email: [memberservices@woodturner.org](mailto:memberservices@woodturner.org).









Website: <https://www.woodturner.org/>

## Des Moines Woodturners Calendar

Event	Date	Refreshments
Chapter Meeting	May 9, 2026, 10 AM & 1 PM	Myles Hegstrom
Networking Meeting	May 27, 2026, 9:30 AM	Tom Golding
America's State Fair (proposed)	May 29 to July 19	Iowa State Fairgrounds (America 250th)
Chapter Meeting	June 13, 2026, 1 PM	Roger Nurnberg
Networking Meeting	June 24, 2026, 9:30 AM	Dan Carlson
Chapter Meeting	July 11, 2026, 1 PM	Scott Smith
Networking Meeting	July 22, 2026, 9:30 AM	Steve Mumford
Iowa State Fair	August 13 - 23, 2026	Iowa State Fairgrounds
Networking Meeting	August 26, 2026, 9:30 AM	
Chapter Meeting	September 12, 2026, 1 PM	Michael Johnson
Networking Meeting	September 23, 2026, 9:30 AM	Myles Hegstrom
Chapter Meeting	October 10, 2026, 1 PM	Dan MacAlpine
Networking Meeting	October 28, 2026, 9:30 AM	Kepler Johnson
Chapter Meeting	November 14, 2026, 1 PM	Maurice & Bryan Herold
*Networking Meeting	*November 18, 2026, 9:30 AM	
Chapter Meeting	December 12, 2026, 1 PM	John Amberg
*Networking Meeting	*December 16, 2026, 9:30 AM	
Chapter Meeting	January 9, 2027, 1 PM	
Networking Meeting	January 27, 2027, 9:30 AM	
Chapter Meeting	February 13, 2027, 1 PM	
Networking Meeting	February 24, 2027, 9:30 AM	
Chapter Meeting	March 13, 2027, 1 PM	
Networking Meeting	March 24, 2027, 9:30 AM	
Chapter Meeting	April 10, 2027, 1 PM	
Networking Meeting	April 28, 2027, 9:30 AM	
Chapter Meeting	May 8, 2027, 1 PM	
Networking Meeting	May 26, 2027, 9:30 AM	
* Rescheduled due to Holiday		



## Board Members and Officers

President: <b>Dennis Anderson</b> (515) 975-8573 <a href="mailto:dennis.anderson.dca@gmail.com">dennis.anderson.dca@gmail.com</a>		Treasurer: <b>Stan Merrell</b> (515) 491-5411 <a href="mailto:srmerrell1@gmail.com">srmerrell1@gmail.com</a>	
Vice President: <b>Mark Hayes</b> (515) 520-0826 <a href="mailto:mahayes@netins.net">mahayes@netins.net</a>		Training: <b>Tad Tadlock</b> (515) 201-7403 <a href="mailto:tad4tahoe@aol.com">tad4tahoe@aol.com</a>	
Secretary: <b>Will Zitterich</b> (515) 232-1765 <a href="mailto:wzitterich@mchsi.com">wzitterich@mchsi.com</a>		Membership: <b>Dan Carlson</b> (515) 720-0637 <a href="mailto:dano1466@yahoo.com">dano1466@yahoo.com</a>	
Programs: <b>Tara Kinder</b> (319) 939-1727 <a href="mailto:tjkinder1994@gmail.com">tjkinder1994@gmail.com</a>		Safety: <b>Mike Hamilton</b> (515) 822-6771 <a href="mailto:kmhamilton9@msn.com">kmhamilton9@msn.com</a>	

## Links to the DMWT Website

<a href="#">Meetings and Events</a>	<a href="#">Woodturning Articles and Plans</a>
<a href="#">Chapter Library List</a>	<a href="#">Contact Board Members and Volunteers</a>
<a href="#">Membership Application Form</a>	

## Des Moines Woodturners Wearables



Members wanting Des Moines Woodturners logo embroidered on clothing are advised to purchase shirts, sweatshirts or turning smocks of their choice and style. These must be BRAND NEW and UNWASHED and can be delivered to any officer or board member. When enough items are collected to meet minimums, they will be taken to the embroiderer. Be sure to attach a note with your name to the collar of each garment submitted indicating if and how you want your name embroidered along with the Chapter logo. The DM Woodturners logo and your name costs \$16.00 paid at the time the item is given to Rob Beattie. Chat with **Rob Beattie** if you have questions. 515-282-4532 or [beattie.r@mchsi.com](mailto:beattie.r@mchsi.com).

## Membership Benefits - Supplier Discounts

One of the benefits of DMWT club membership are discounts with participating suppliers. We strongly encourage you to use local suppliers whenever possible. Before they ring you up, show discount suppliers your Des Moines Woodturners membership card. BUY LOCAL when you can, Mail Order when you have no other choice!!

RightAngleNow	DMWT Member <b>Gil Lea</b> offers a 20% discount on sharpening jigs	<a href="https://www.rightanglenow.com/">https:// www.rightanglenow.com/</a>	515-205-7522
Ace Hardware - Ankeny	10% except for Sale Items, Repair Services, Rental and Gasoline Powered Equipment	3020 SW Oralabor Road Ankeny	515-809-1104
Ace Hardware - Johnston	10% except for Sale Items, Repair Services, Rental and Gasoline Powered Equipment	5800 Merle Hay Rd Johnston	515-276-2854
O-Donnell Ace Hardware	10% Member Discount except for Sale Items, Repair Services, Rentals, Power Tools and Gasoline Powered Equipment	4808 University Des Moines	515-277-0062
O-Donnell Ace Hardware	10% Member Discount except for Sale Items, Repair Services, Rentals, Power Tools and Gasoline Powered Equipment	5715 Hickman Rd Des Moines	515-255-2240
Park Fair Ace Hardware	10% Member Discount except for Sale Items	100 E Euclid Ave Des Moines	515-243-6000
Acme Tools & Equipment - Power Tools	10% Member Discount on Woodworking Accessories. Does not include Sale Items, Power tools or Service and Parts.	629 SW 9th St Des Moines	515-244-4189
Bradley Tool & Fasteners - Sharpening & Equipment Rebuilding	10% Member Discount except sale items, power tools/equipment, tool/equipment parts, tool renovation/repair services.	6250 NW Beaver Dr Ste A4 Johnston	515-331-0878
Sharpening Solutions - Des Moines	Approximate prices are \$1/inch for planer/jointer knives, and \$15 for standard circular saw blades. Additional charges for triple chip grind or high tooth count blades	2614 E Douglas Ave Des Moines	515-577-4535
Sherwin Williams - Paint & Finish	20% discount off all in stock regular price items. 5% discount off in stock sale items. Up to 30% off of the Sher-Wood wood finishes.	Altoona 3770 8th Street SW Ste F	515-967-6974
Sherwin Williams - Paint & Finish	20% discount off all in stock regular price items. 5% discount off in stock sale items. Up to 30% off of the Sher-Wood wood finishes.	Ames 1624 South Duff Ave	515-232-2124
Sherwin Williams - Paint & Finish	20% discount off all in stock regular price items. 5% discount off in stock sale items. Up to 30% off of the Sher-Wood wood finishes.	Ankeny 817 E 1st St	515-964-7890
Sherwin Williams - Paint & Finish	20% discount off all in stock regular price items. 5% discount off in stock sale items. Up to 30% off of the Sher-Wood wood finishes.	Clive 1985 NW 94th St	515-251-2973
Sherwin Williams - Paint & Finish	20% discount off all in stock regular price items. 5% discount off in stock sale items. Up to 30% off of the Sher-Wood wood finishes.	Des Moines 515 16th St *Commercial*	515-280-3365
Sherwin Williams - Paint & Finish	20% discount off all in stock regular price items. 5% discount off in stock sale items. Up to 30% off of the Sher-Wood wood finishes.	Des Moines 5408 Douglas Ave	515-278-0481
Sherwin Williams - Paint & Finish	20% discount off all in stock regular price items. 5% discount off in stock sale items. Up to 30% off of the Sher-Wood wood finishes.	Des Moines 1040 E Army Post Rd Ste A	515-285-0072
Sherwin Williams - Paint & Finish	20% discount off all in stock regular price items. 5% discount off in stock sale items. Up to 30% off of the Sher-Wood wood finishes.	Grimes 2570 E 1st St	515-300-9407
Sherwin Williams - Paint & Finish	20% discount off all in stock regular price items. 5% discount off in stock sale items. Up to 30% off of the Sher-Wood wood finishes.	Marshalltown 105 Nicholas Dr	641-752-0229
Sherwin Williams - Paint & Finish	20% discount off all in stock regular price items. 5% discount off in stock sale items. Up to 30% off of the Sher-Wood wood finishes.	Oskaloosa 117 High Ave W	641-673-8441
Sherwin Williams - Paint & Finish	20% discount off all in stock regular price items. 5% discount off in stock sale items. Up to 30% off of the Sher-Wood wood finishes.	Ottumwa 1231 Theatre Dr	641-684-6564
Sherwin Williams - Paint & Finish	20% discount off all in stock regular price items. 5% discount off in stock sale items. Up to 30% off of the Sher-Wood wood finishes.	Waukee 140 Hickman Rd	515-987-4048
Sherwin Williams - Paint & Finish	20% discount off all in stock regular price items. 5% discount off in stock sale items. Up to 30% off of the Sher-Wood wood finishes.	West Des Moines 830 Grand Ave	515-226-0603
True Value Hardware - West Des Moines	10% Member Discount except for Sale Items, Repair Services, Rental, Electrical and Gasoline Powered Equipment	63rd & Grand West Des Moines	515-279-9905
White Cap Supply - Power Tools & Fasteners	10% Member Discount except for Power Tools and Sale Items.	1631 2nd Ave. Des Moines	515-243-6969
Woodcraft Store - Tools & Supplies - Iowa City	10% Member Discount, except tools that have a cord or battery. There are a few specific brands including Festool and SawStop which exclude even non-powered accessories from our discount, to so be sure to ask before purchase.	3 Escort Lane Iowa City, IA	319-259-7175
Woodcraft Store - Tools & Supplies - Kansas City	10% Member Discount except tools that have a cord or battery plus sale items. There are a few other low margin items that the Discount may not apply to so be sure to ask.	8645 Bluejacket Rd Lenexa, Kansas	913-599-2800
Woodsmith Store - Tools & Supplies	5% Member Discount except for Power Tools and Sale Items	2900 University Ave West Des Moines	515-254-9494