

Wood Turning Tool Table

February 14, 2018

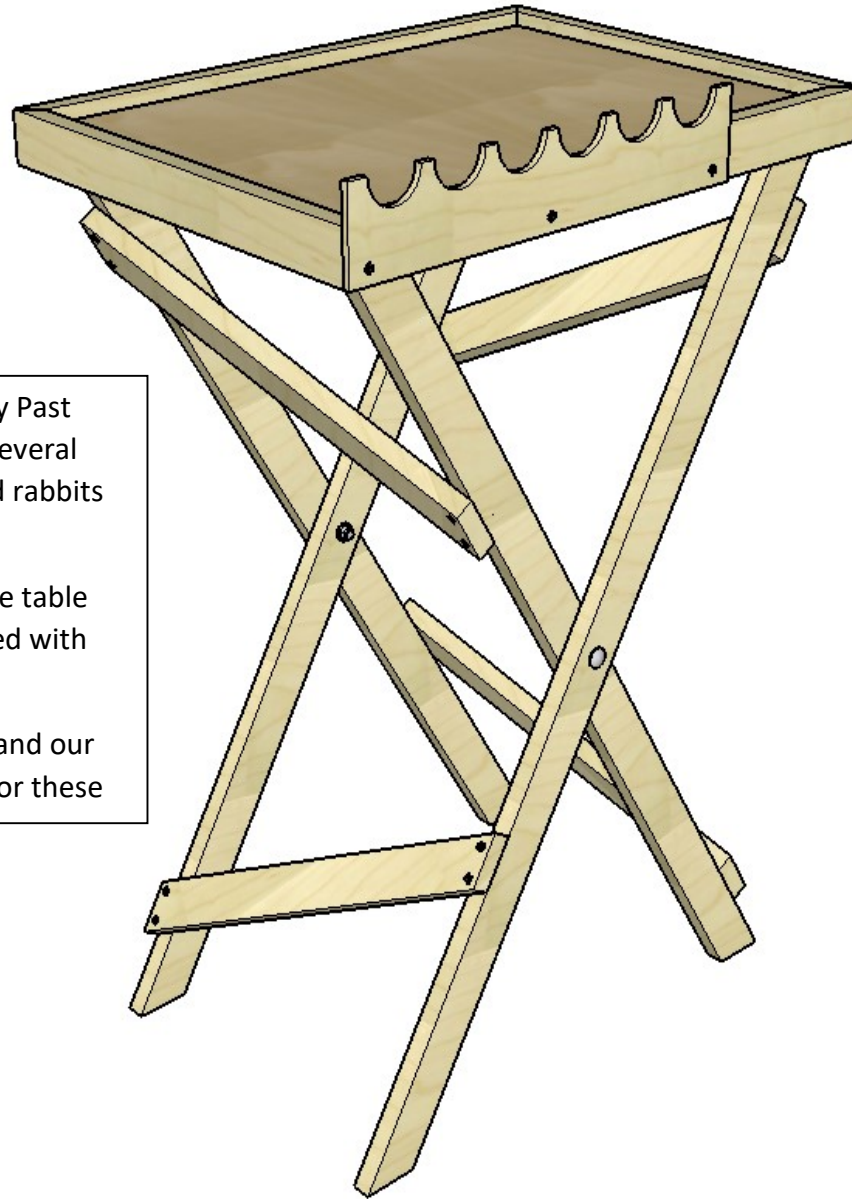

This lathe tool table was developed by Past President Dave Yerian after building several similar tables for a friend that showed rabbits in competition.

These drawings are based on a full size table constructed of hard maple and finished with water-based polyurethane.

Thanks to Dave Yerian for the design and our current Program Chair Tom Whalley for these

Top Assembly

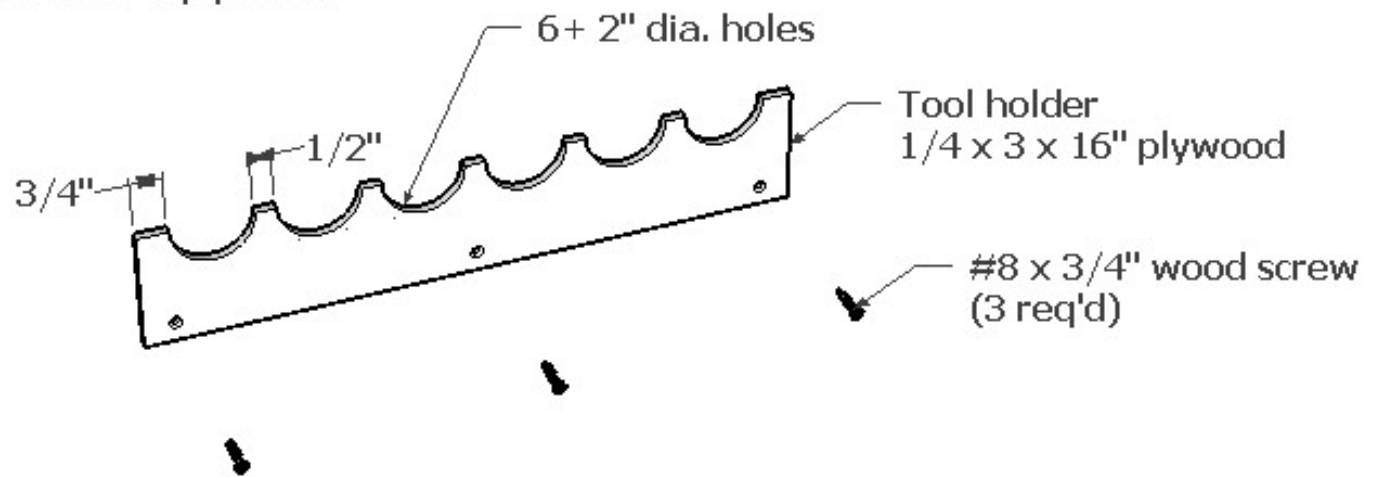
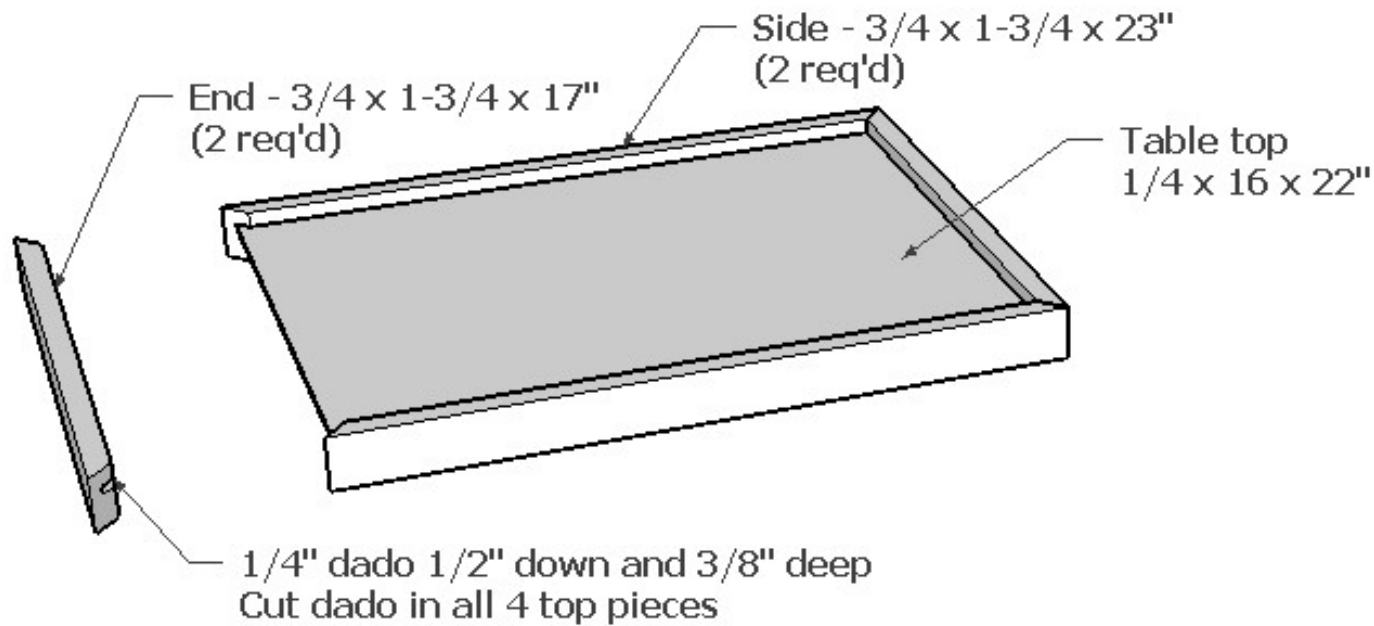

Leg Assembly

