

The 40/40 Bowl Gouge

To set up the grinder platform, make sure that there is a 40 degree angle where it contacts the wheel.

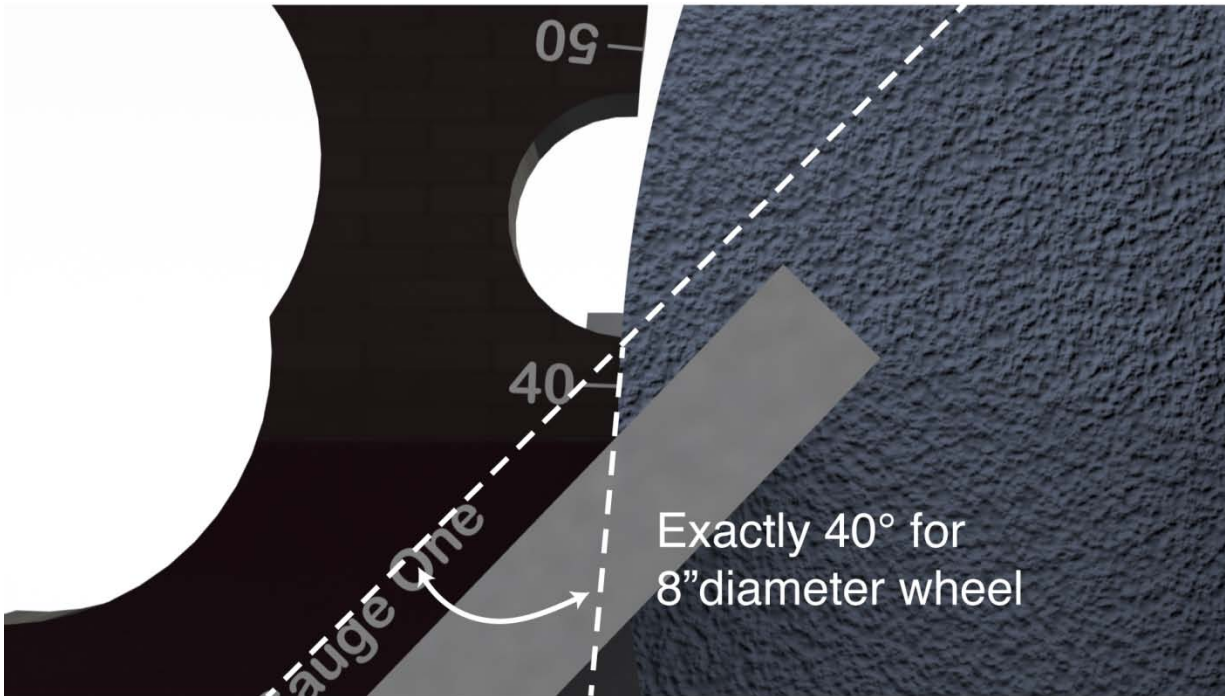

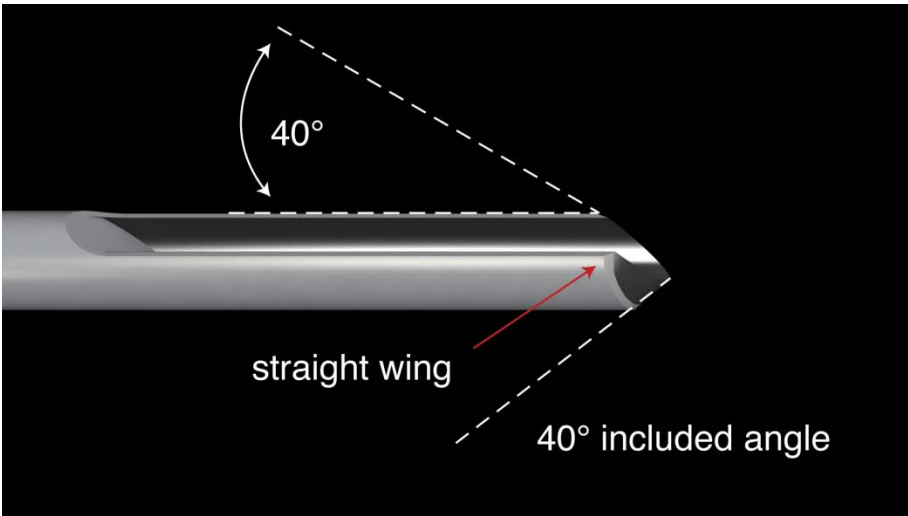

The 40/40 bowl gouge gets its name from the grind, which produces a 40 degree bevel on the nose and wings of the gouge, with straight wings which are swept back at a 40 degree angle.

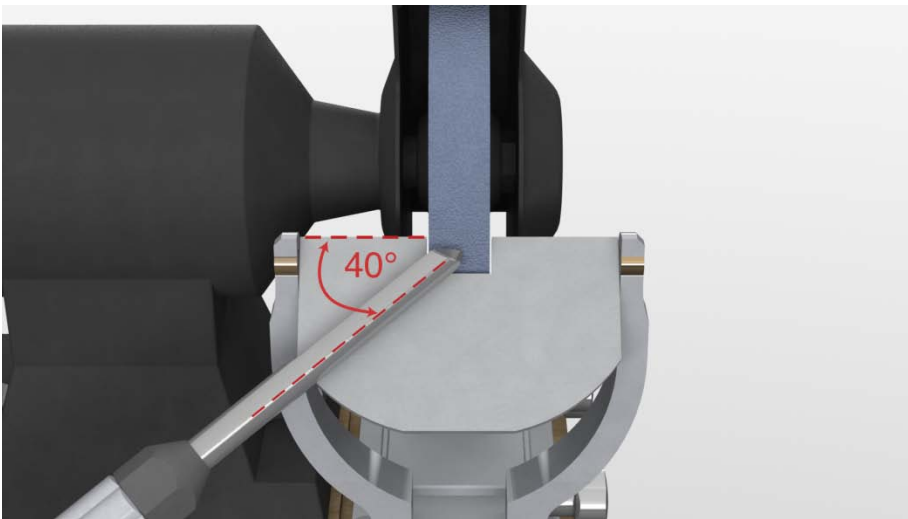

In order to create the 40 degree swept back wings, place the tool on the platform at 40 degrees from horizontal.

When grinding the wing, the flute should be slightly open, so that the inside wall of the wing is parallel with the surface of the platform.

Edge of flute parallel to platform

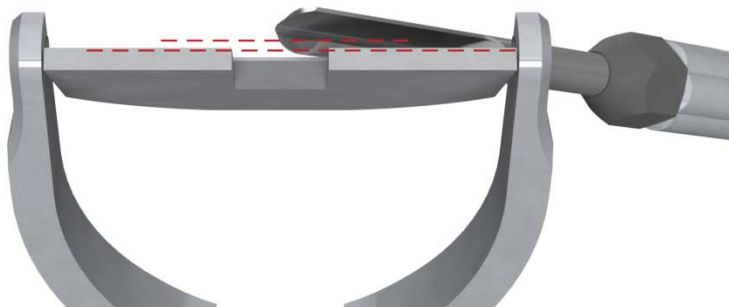

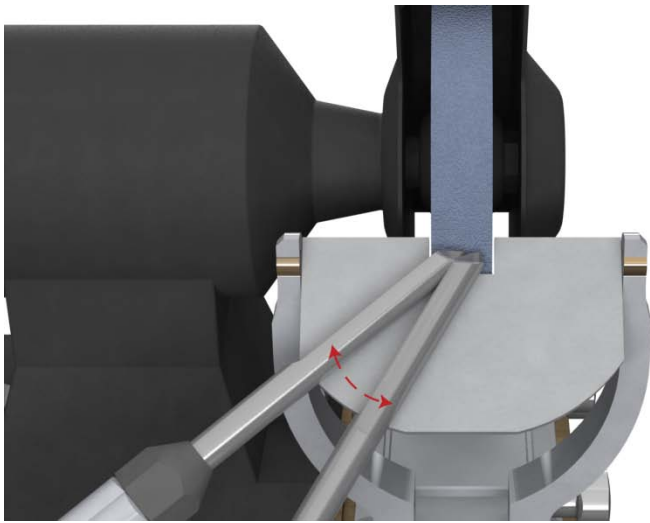

swing tool to
create wing

To grind the wing, rock the handle up and down slightly, making sure to keep the tool flat on the surface of the platform.

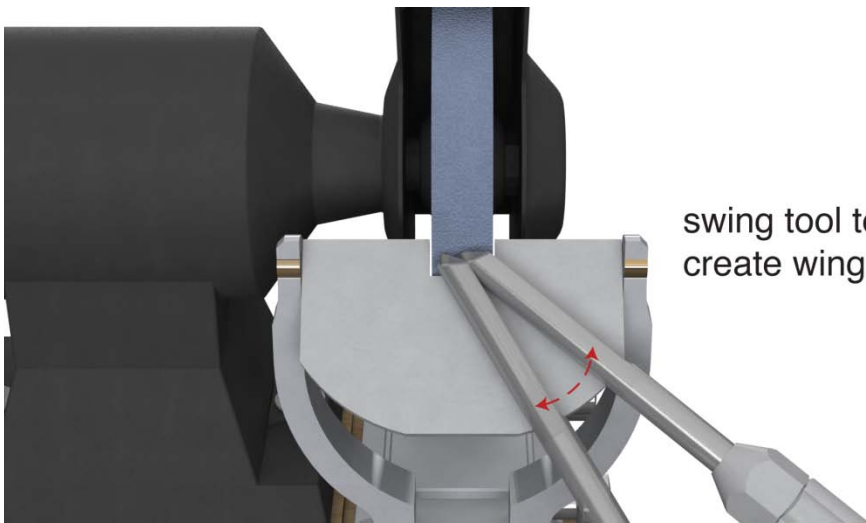

swing tool to
create wing

Repeat for the right wing.

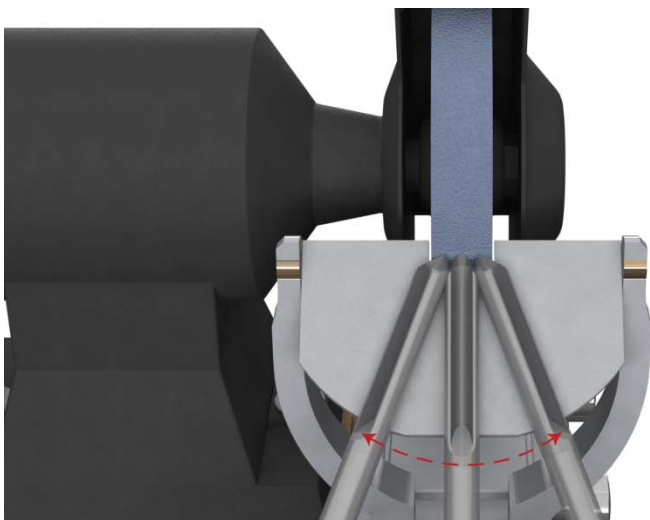

rotate tool to
create nose

To grind the nose of the gouge, twist and swing at the same time.